

Fig. 24

DELAY SETTINGS AND CROSSOVER FREQUENCIES

KPT-325

	12 dB/Octave		24 dB/Octave	
	800 Hz	1 KHz	800 Hz	1 KHz
LF Delay	.3 ms	.3 ms	0	0
HF Delay	0	0	.1 ms	.1 ms

KPT-904

	12 dB/Octave		24 dB/Octave	
	800 Hz	1 KHz	800 Hz	1 KHz
LF Delay	.3 ms	.3 ms	0	0
HF Delay	0	0	.1 ms	.1ms

KPT-941

	12 dB/Octave		24 dB/Octave	
	500 Hz	800 Hz	500 Hz	800 Hz
LF Delay	1.6 ms	1.6 ms	1.2 ms	1.2 ms
HF Delay	0	0	0	0

KPT-941-T

Delay and Crossover Frequency are set by THX Crossover			

KPT-535

	12 dB/Octave				24 dB/Octave			
	400 Hz	500 Hz	2 KHz	3 KHz	400 Hz	500 Hz	2 KHz	3 KHz
LF Delay	1.4 ms	1.4 ms	--	--	.7 ms	.7 ms	--	--
MF Delay	0	0	--	--	0	0	--	--
HF Delay	--	--	1.3 ms	1.3 ms	--	--	1.1 ms	1.1ms

KPT-Jubilee

	12 dB/Octave				24 dB/Octave			
	350 Hz	500 Hz	800 Hz	1.2 KHz	350 Hz	500 Hz	800 Hz	1.2 KHz
LF Delay	0	0	--	--	0	0	--	--
MF Delay	3.0 ms	3.0 ms	--	--	3.8 ms	3.8 ms	--	--
HF Delay	--	--	3.5 ms	3.5 ms	--	--	3.9 ms	3.9 ms

KPT-MCM-3 Grand System

	12 dB/Octave				24 dB/Octave			
	300 Hz	500 Hz	800 Hz	1 KHz	300 Hz	500 Hz	800 Hz	1 KHz
LF Delay	0	0	--	--	0	0	--	--
MF Delay	3.4 ms	3.4 ms	--	--	5.0 ms	5.0 ms	--	--
HF Delay	--	--	2.7 ms	2.7 ms	--	--	3.9 ms	3.9 ms



Klipsch Professional Theater Speaker Systems

Installation Manual

Applicable for the Installation and assembly of the following products:

Screen Systems

KPT-MCM Grand
KPT-Jubilee® Stage System
KPT-941-T (THX® – Approved)
KPT-941
KPT-535
KPT-904
KPT-325

Surround Systems

KPT-250
KPT-200 (THX® – Approved)
KPT-100 (THX® – Approved)
KPT-110

SUBWOOFERS

KPT-684 (THX® – Approved)
KPT-484



Welcome to the Klipsch line of Professional Theater Speaker Systems!

Since the earliest days of amplified sound systems, Klipsch has utilized the latest concepts in loudspeaker design, surpassing the expectations of concurrent fidelity. Today, by combining our design excellence with a solid tradition of sonic reproduction quality, Klipsch provides a comprehensive family of professional theater speakers, ranging from compact systems perfect for small auditoriums, mixing suites and viewing rooms, to large four-way horn-loaded systems applicable for installation in the largest cinema venues.

In Klipsch designs, you will find technical updates on traditional high quality cinema sound systems, taking into consideration the digital sound sources of today. Thanks to the Klipsch Tractrix® Horns used on high frequency and mid-bass components, the Klipsch Professional Theater Speaker Systems offer wider dynamics, controlled coverage, smoother power transfer functions, lower distortion and superior efficiency, all in a broad range of available systems.

Included in the following pages are installation instructions for the Klipsch family of professional theater sound products. If you have any questions or need more information, please contact Klipsch directly at 1-800-KLIPSCH. Our technical support staff will be happy to assist you.

Sincerely

Fred S Klipsch



Fig. 22

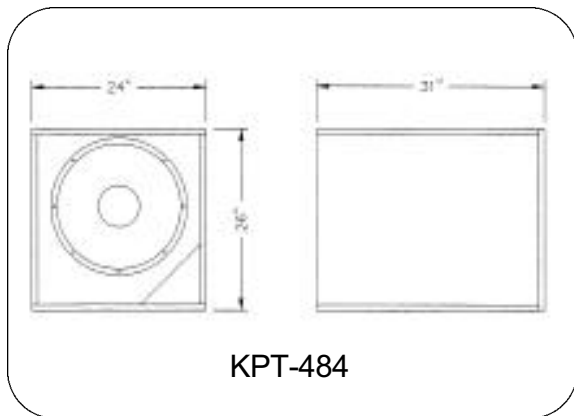
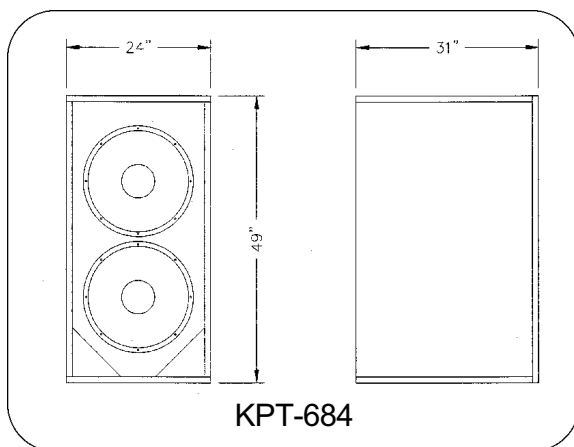

Fig. 23



Mechanical Installation Drawings for KPT-484 and KPT-684

Please refer to figures. 22 and 23. These figures provide dimensions required for creating baffles or for proper placement behind the screen.

Connectors can be made to the system by using the terminator panel located on top of the unit.

Screen Sound System Setup and Alignment

After assembling the speakers, but prior to operation, be sure that wiring connections are correct and that the installed systems are free from problems, utilizing the following steps:

- 1) At the loudspeaker component end of the cable run, "short" the positive and negative connections for each frequency section together, and verify that your resistance meter reads the short when measured from the amplifier end.
- 2) Verify that all amplifier channels and speaker components have been wired correctly and are in proper polarity.
- 3) Set the electronic crossover and amplifier channels as per manufacturer recommended settings. Refer to the speaker component specifications for each system.
- 4) With a low level pink noise or frequency generator signal source, verify that the low frequency amplifier and processor outputs for each of the systems is feeding the proper speaker component(s). Do the same for all of the amplifier and speaker sections, across all of the installed systems.
- 5) After pre-testing the system as indicated above, verifying operation and completing a basic gain staging setup, to check for rattles, buzzes or vibrations from the hardware, use a variable frequency oscillator or pink noise source to "sweep" the system between 20Hz and 1000Hz at LOW, MEDIUM, and then HIGH volume.
- 6) Complete a preliminary gain staging of the entire system per applicable processor specifications, then verify that component aiming properly addresses listening requirements throughout the house.
- 7) Complete proper final gain staging per processor recommendations.

Mechanical Installation Drawings for KPT-250, KPT-200 and KPT-100 Surround Sound Speakers

Please refer to the following drawings for installation details: Figures 17, 18, 19 and 20.

The bolt locations shown in "A" on Fig. 17 are common to models KPT-250, KPT-200 and KPT-100 surround sound speakers, and are used when mounting the speakers using a Goldberg bracket. The bolt hole locations shown at "B" in Fig. 17 are used when mounting the speakers using either an APC or OmniMount bracket.

Mechanical Installation Drawing for KPT-110 Surround Sound Speaker

Figure 21 shows the basic dimensions for the KPT-110. Location "A" bolts and washers are to be used when mounting the speaker with a Goldberg bracket.

Surround Sound System Installation

Installation drawings for the surround sound speaker systems are located in the following section. All of the systems are pre-assembled for installation on-site, and include passive frequency dividing networks. Please refer to the specification page for power and impedance information.

Connections to the internal passive frequency dividing networks are made on the termination panel located in the top of the units. Note that models KPT-200 and KPT-100 include internal SMPTE/ISO 2696 X-curve de-emphasis.

Klipsch surround speaker mounting hardware is designed for readily available Goldberg, APC and OmniMount brackets.

Fig. 17

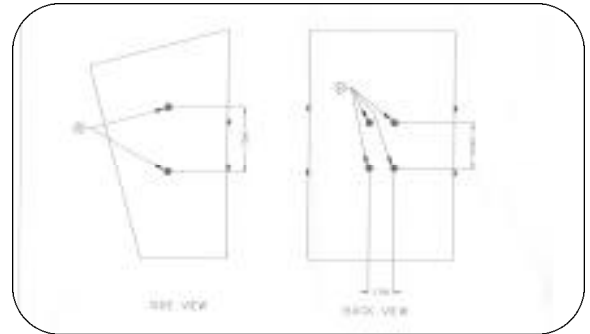

Fig. 18

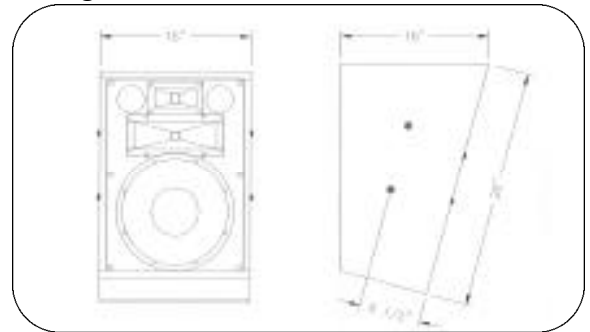

Fig. 19

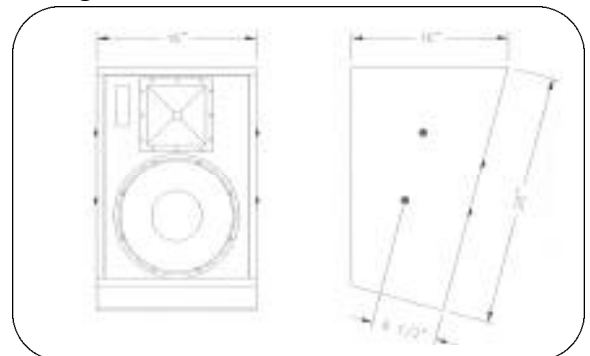

Fig. 20

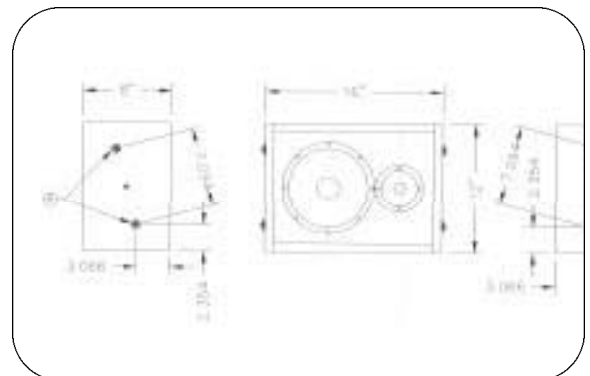

Fig. 21

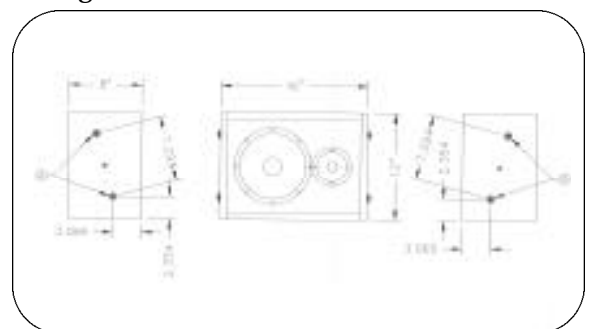

Table of Contents

General Introduction	Pg. 2-5
Safety	
Amplification	
Wire Gauge	
Crossovers	Pg 5-6
General Aiming Goals	
Behind-The-Screen and Stage Systems	Pg 6
Placement Considerations	
Vertical	
Horizontal	
Mechanical Installation for KPT-MCM-4 Grand	Pg 7
Mechanical Installation for KPT-MCM-3 Grand	Pg 7
Mechanical Installation for KPT-Jubilee™	Pg 8
Mechanical Installation for KPT-941-T	Pg 8
Mechanical Installation for KPT-941	Pg 9
Mechanical Installation for KPT-904	Pg 9
Mechanical Installation for KPT-535	Pg 10
Mechanical Installation for KPT-325	Pg 10
Mechanical Installation for KPT-684	Pg 11
Mechanical Installation for KPT-484	Pg 11
Mechanical Installation for KPT-250, KPT-200, KPT-100	Pg 11
Mechanical Installation for KPT-110	Pg 11
Surround Sound System Installation	Pg 11
Screen Sound System Setup and Alignment	Pg 12
Wiring Detail Example	Pg 13
System Specifications	Pg 13
Delay Settings	Pg 13
Crossover Frequencies	Pg 13
Contact and Service Info	Pg 14

Klipsch Professional Theater Speaker Systems

The hardware required to mount the component modules is included with the speaker components on all Klipsch behind-the-screen and stage speaker systems. Hardware

primarily consists of brackets, yokes, bolts, nuts and washers for mounting and properly aiming the mid-bass and high frequency horns and drivers above the low frequency enclosures. The surround sound speakers, intended for wall mounting, are pre-drilled for use with industry standard Goldberg, APC and OmniMount® brackets. Please refer to the loudspeaker model installation diagrams in the following sections for specific assembly details.

Safety

After assembling the components on each speaker system, but before operation, all bolts and nuts should be double-checked for proper seating and tightness. Due to the weight and size of the components, damage could occur if the devices were to become unattached.

Amplification

For B-chain amplifier power matching, please refer to the specifications for each component module. Amplifiers should be overrated to ensure available dynamic headroom and freedom from distortion on loud signal passages. Level capabilities in the house should meet or exceed your specific processor system standards when speaker component specifications are factored in. Note that nominal dialogue levels in modern theaters are typically 85dB or greater, with effect and music levels at a 105dB average. When using passive crossovers (as opposed to actively dividing signals for the low, mid-bass, high frequency and optional extended high frequency sections), Klipsch recommends designing the system with 6dB of amplifier headroom.

Wire Gauge

The choice of gauge for speaker interconnect wire plays a major role in the power transfer efficiency between amplifiers and speakers. Signal loss per distance charts for the various gauges of speaker wire and loudspeaker impedances indicate that the largest gauge of wire should be used, whenever possible, to minimize insertion loss, amplifier loading and frequency response non-linearities.

Crossovers

Although passive crossovers are available for a number of the Klipsch screen and stage systems, there are advantages to using active crossovers. By actively dividing the frequency sections for the systems, less power is lost to heat in the passive crossover, and device control (damping factor) is greatly improved. In virtually every case, the speaker system performance is improved through bi- or tri-amplification. Of course, the performance improvements must be weighed against the cost of additional amplifier channels.



Fig. 13

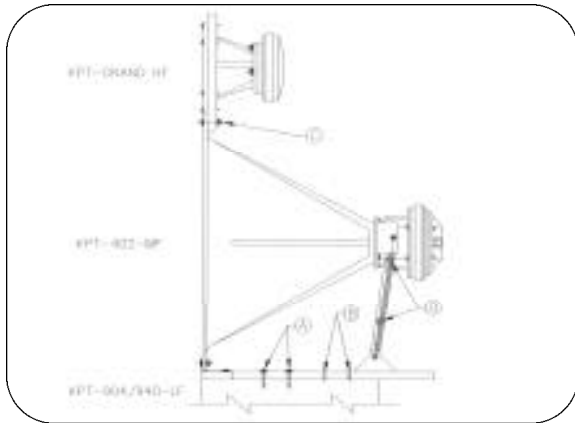

Fig. 14

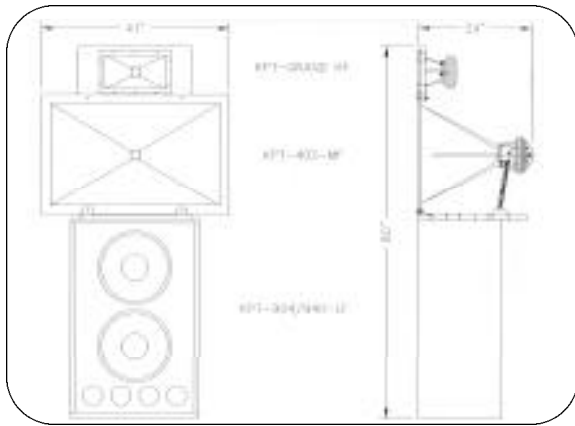

Fig. 15

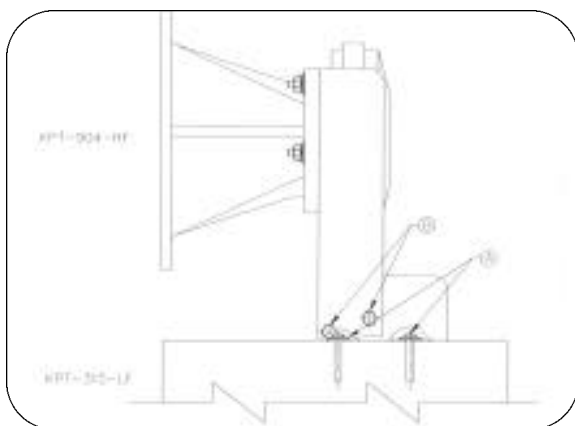
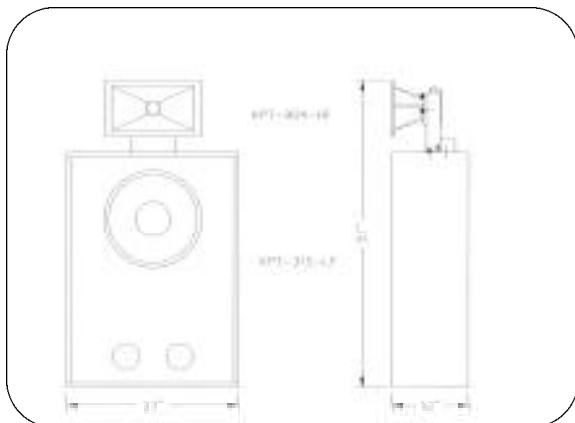

Fig. 16



Mechanical Installation Drawings for KPT-535

Please refer to the following drawings for assembly details:
Figures 13 and 14.

After unpacking all components, locate the KPT-402 compression driver and horn. Attach the driver to the horn using supplied hardware.

Locate the two 1/4" -20 screws on top of the KPT-904/940-LF. Remove the two screws and washers. Place the KPT-402-MF unit on top of the KPT-904/940-LF, making sure that the hole/slot as indicated by "A" in Fig. 13 lines up with the holes in the KPT-904/940-LF. Reinstall the screws and washers. Adjust the horizontal angle as desired and tighten the screws.

Locate the KPT-Grand-HF. Locate the two 1/4" -20 on the KPT-Grand-HF. Remove the two screws and washers. Place the KPT-Grand-HF on top of the KPT-402-MF and align the holes. Reinstall the screws and washers and tighten screws as shown at "C" on Fig. 13.

Locate the 1/4" -20 nuts as shown at "D" in Fig. 13. To adjust the vertical angle, loosen the nuts and adjust the horns until the desired vertical angle is achieved. Tighten the nuts.

Mechanical Installation Drawings for KPT-325

Please refer to the following drawings for assembly details:
Figures 15 and 16.

After unpacking all the components, locate the two 1/4" -20 screws on top of the KPT-315-LF. Remove the two screws and washers. Place the KPT-904-HF unit on top of the KPT-315-LF, making sure that the hole/slot as indicated by "A" in Fig. 15 lines up with the holes in the KPT-315-LF. Reinstall the screws and washers. Adjust the horizontal angle as desired and tighten the screws.

Locate the 1/4" -20 bolts/nuts on both sides of the bracket as shown at "B" in Fig. 15. To adjust the vertical angle, loosen the bolts and nuts and adjust the horn until the desired vertical angle is achieved. Tighten the bolts and nuts.

Mechanical Installation Drawings for KPT-941

Please refer to the following drawings for assembly details: Figures 9 and 10.

After unpacking all components, locate the KPT-941 HF compression driver and horn. Attach the driver to the horn using supplied hardware.

Locate the two $\frac{1}{4}$ " -20 screws on top of the KPT-904/940-LF. Remove the two screws and washers. Place the KPT-941-HF unit on top of the KPT-904/940-LF, making sure that the hole/slot as indicated by "A" in Fig. 9 lines up with the holes in the KPT-904/940-LF. Reinstall the screws and washers. Adjust the horizontal angle as desired and tighten the screws.

Locate the $\frac{1}{4}$ " -20 nuts as shown at "C" in Fig. 10. To adjust the vertical angle, loosen the nuts and adjust the horn until the desired vertical angle is achieved. Tighten the nuts.

Fig. 9

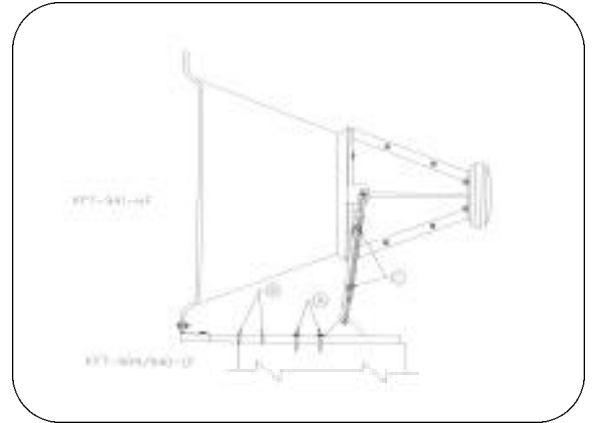

Fig. 10

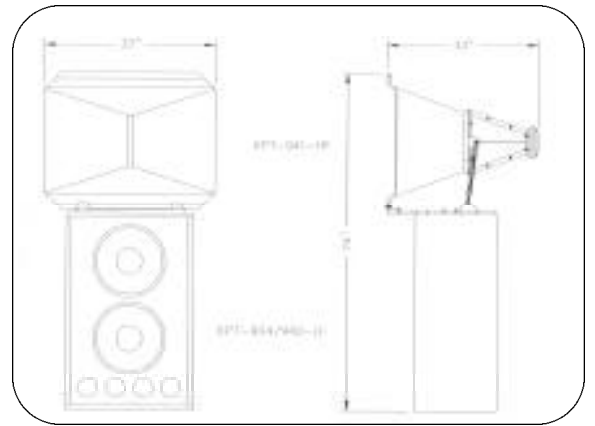

Fig. 11

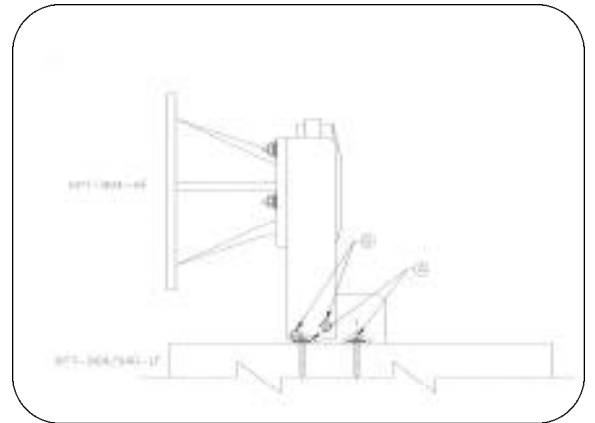
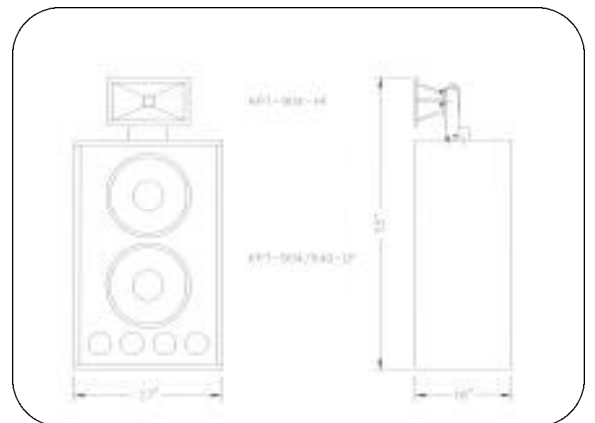

Fig. 12



Mechanical Installation Drawings for KPT-904

Please refer to the following drawings for assembly details: Figures 11 and 12:

After unpacking all the components, locate the two $\frac{1}{4}$ " -20 screws on top of the KPT-904/940-LF. Remove the two screws and washers. Place the KPT-904-HF unit on top of the KPT-904/940-LF, making sure that the hole/slot as indicated by "A" in Fig. 11 lines up with the holes in the KPT-904/940-LF. Reinstall the screws and washers. Adjust the horizontal angle desired and tighten the screws.

Locate the $\frac{1}{4}$ " -20 bolts and nuts on both sides of the bracket as shown at "B" in Fig. 11. To adjust the vertical angle, loosen the bolts and nuts, and adjust the horn until the desired vertical angle is achieved. Tighten the bolts and nuts.

Optional passive crossovers are available for the following systems

KPT-941
KPT-535 (Mid-bass to high frequency only)
KPT-904
KPT-325

Recommended crossover frequencies for the various components can be found in the system specification section.

GENERAL AIMING GOALS

Klipsch theater audio products utilize Tractrix® Horns in the screen and stage systems' mid-bass and high-frequency devices for precise coverage and projection. By making the appropriate tilt-down adjustments on the supplied installation hardware, and, if required, toeing-in the left and right outside speakers, you can achieve proper and precise vertical and horizontal aiming of the system. The degree of toe-in will be determined by the depth and width of the auditorium, and the height and distance of the screen from the seating area.

For localization to be effective, audience seating must fall inside the horizontal and vertical coverage patterns of the outside high frequency horns. All Klipsch theater speaker systems utilize consistent coverage angles of 80 degrees or higher, with the larger auditorium-appropriate systems providing nominal 90 degree coverage angles. Refer to the specification page for component section coverage data.

BEHIND-THE-SCREEN AND STAGE SYSTEMS

Installation assembly drawings for the behind-the-screen and stage systems are located in the following section. All of the systems are designed for assembly on-site and only require a few tools to complete. Electronic crossover frequency dividing network specifications and delay settings are provided in the delay and crossover frequency section. Several of the systems have optional passive crossovers available. Refer to the previous page for systems with available passive crossovers.

PLACEMENT CONSIDERATIONS

VERTICAL POSITIONING

Behind-the-screen speaker systems should generally be located with the highest frequency horn section positioned at approximately two-thirds the height of the perforated screen. The front edge of the high frequency horns, after tilt-down and aiming, should be as close to the back of the screen as possible, without actually touching it. This will help ensure that a minimal amount of back-reflection from the screen is created, minimizing "comb filter" frequency response anomalies.

HORIZONTAL POSITIONING

For proper localization, seating areas should fall inside the horizontal and vertical coverage patterns of the high frequency horn devices. In L-C-R, three-channel, behind-the-screen systems, the speakers should be spaced an equal distance apart, with the outside left and right speakers immediately inside of the unmasked screen area of the widest format projected (typically 2.35:1). When the screen is masked to smaller formats (such as 1.85:1), acoustically transparent masking should be used to avoid blocking of the high frequencies. In five-channel behind-the-screen systems, the speakers should be positioned equidistant from each other across the stage.

The exact amount of toe-in and tilt will be determined by the depth and width of the auditorium, and the height and distance of the screen from the seating area. The outside speakers' patterns (on axis) should cross two-thirds of the way to the rear. In doing this, the audience members seated closer to the screen will be slightly off-axis when the speakers are aimed toward the back wall, with levels balancing evenly owing to the inverse square distance law, front to rear. The Klipsch Tractrix® Horns in the high-frequency and mid-bass sections will provide linear frequency response, although at reduced levels, as the listening angle off-axis is increased, up to the pattern limits of the horn components.

Mechanical Installation Drawings for KPT-MCM-4 Grand.

Fig. 1

Please refer to the following drawings for assembly details:
Figures 1 and 2.

After unpacking all components, locate the KPT-941 HF compression driver and horn. Attach the driver to the horn using supplied hardware.

Locate the two 1/4"-20 screws on top of the KPT-XII. Remove the two screws and washers. Place the KPT-941-HF unit on top of the KPT-XII, making sure that the hole/slot as indicated by "B" in Fig. 1 lines up with holes in the KPT-XII. Reinstall the screws and washers. Adjust the horizontal angle as desired and tighten screws.

Locate the KPT-Grand-HF. Locate the two 1/4"-20 screws on the KPT-Grand-HF. Remove the two screws and washers. Place the KPT-Grand-HF on top of the KPT-941-HF and align the holes. Reinstall the screws and washers and tighten screws as shown at "D" in Fig. 1.

Locate the 1/4"-20 nuts as shown at "A" in Fig. 1. To adjust the vertical angle, loosen the nuts and adjust horns until desired vertical angle is achieved. Tighten nuts.

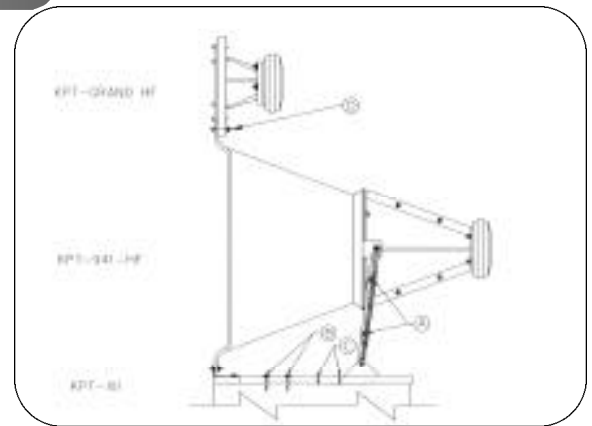
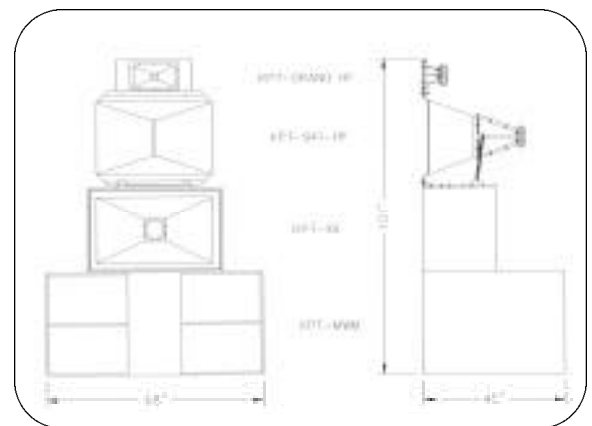

Fig. 2



Mechanical Installation Drawings for KPT-MCM-3 Grand

Fig. 3

Please refer to the following drawings for assembly details:
Figures 3 and 4.

After unpacking all components, locate the KPT-941 HF compression driver and horn. Attach the driver to the horn using supplied hardware.

Locate the two 1/4"-20 screws on top of the KPT-XII. Remove the two screws and washers. Place the KPT-941-HF unit on top of the KPT-XII, making sure that the hole/slot as indicated by "B" in Fig. 3 lines up with the holes in the KPT-XII. Reinstall the screws and washers. Adjust the horizontal angle as desired and tighten screws.

Locate the 1/4"-20 nuts as shown at "A" in Fig. 3. To adjust the vertical angle, loosen the nuts and adjust the horn until the desired vertical angle is achieved. Tighten the nuts.

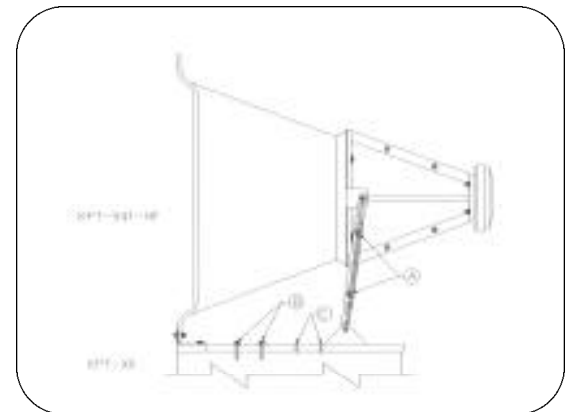

Fig. 4

